

គូសតាមស្នាមចុចគំនូសខ្សែ



ស្ត្រេន QR Code

សាលាមត្តេយ្យ ថ្នាក់កម្រិត

ឈ្មោះ: កាលបរិច្ឆេទ

Tracing exercise 1: A person is shown operating a hand crank with a large wheel. A dashed line starts with a horizontal arrow labeled '១' pointing right. To the right is an icon of a wrench.

Tracing exercise 2: A person is shown at a sewing machine. A dashed zigzag line starts with an upward arrow labeled '១' and a downward arrow labeled '២'. To the right is an icon of a needle and thread.

Tracing exercise 3: A person is shown standing. A dashed square wave line starts with a horizontal arrow labeled '១' pointing right, followed by a downward arrow labeled '២', an upward arrow labeled '៣', and another horizontal arrow labeled '១'. To the right is an icon of a hammer.

Tracing exercise 4: A person is shown at a camera on a tripod. A dashed arch line starts with a curved arrow labeled '១' pointing down, followed by a downward arrow labeled '២'. To the right is an icon of a camera.

Tracing exercise 5: A person in a uniform is shown. A dashed wave line starts with a curved arrow labeled '១' pointing up, followed by a downward arrow labeled '២', and ends with a horizontal arrow labeled '១'. To the right is an icon of a presentation board.

ត្រូវបំពេញរូបត្រីខាងក្រោមឱ្យរួចរាល់ត្រីខាងលើ ហើយដាក់ពណ៌
 (រាងចតុកោណកែង និងរង្វង់)

សាលាបង្ហាញ ឃ្នកគ្រូត

ឈ្មោះ កាលបរិច្ឆេទ

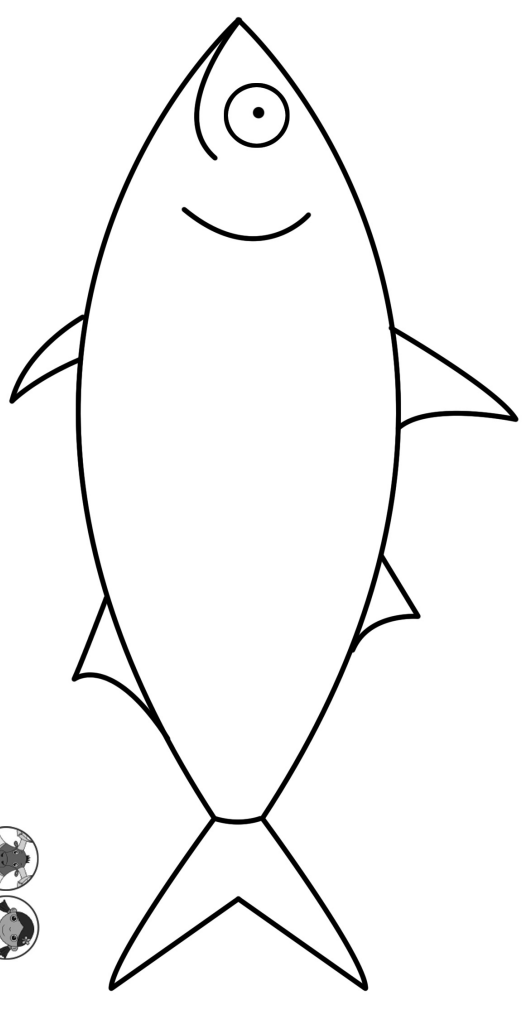
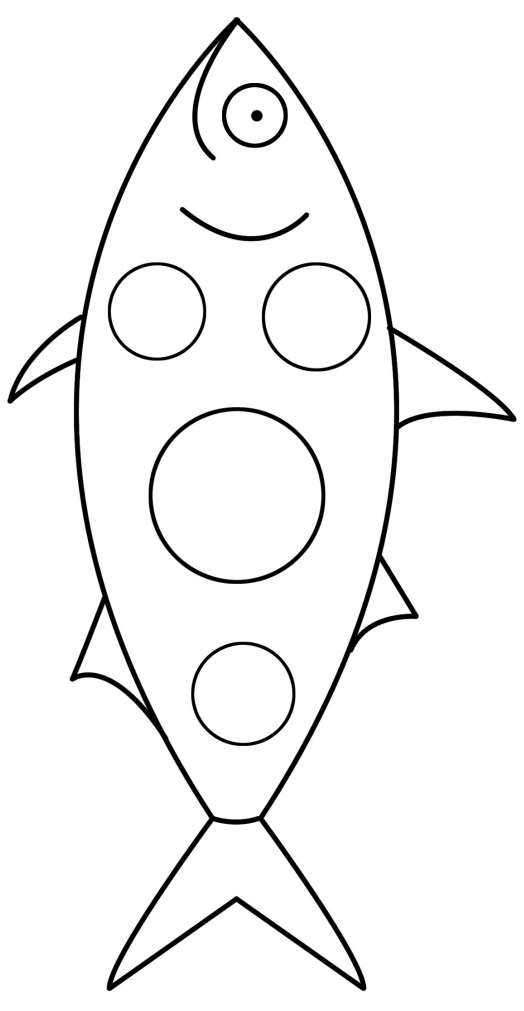
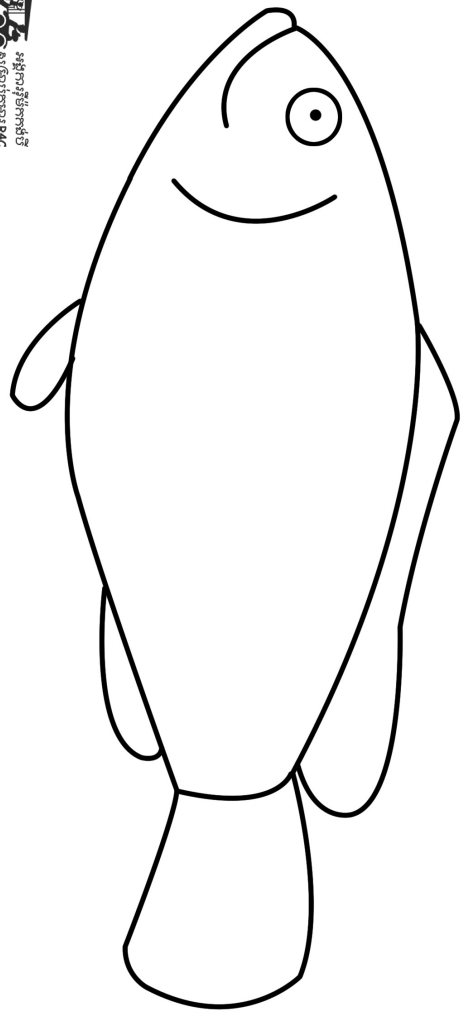
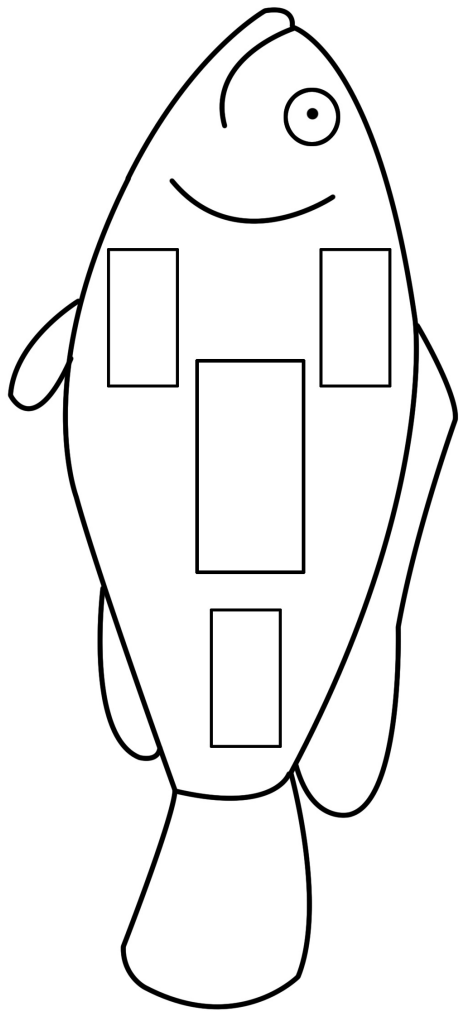

គ្រូបំបៅញ្ជូរប ត្រីខាងក្រោម ឲ្យដូចគ្រូខាងលើ ហើយដាក់ពណ៌
(រាងកាកែវ រាង ត្រីកោណ)

សាលា មន្ត្រី យ្យ ផ្នែក កម្រិត ថ្នាក់ គ្រូ ត

ឈ្មោះ : កាលបរិច្ឆេទ :

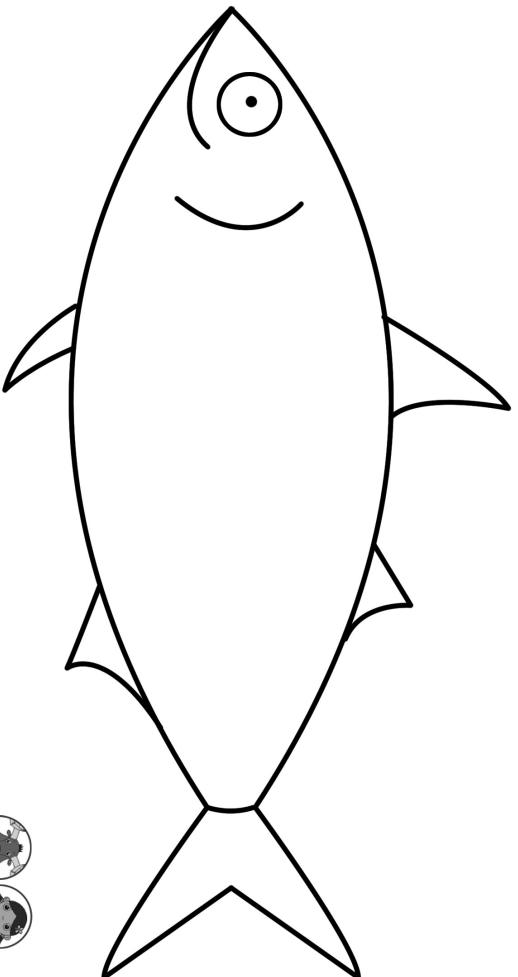
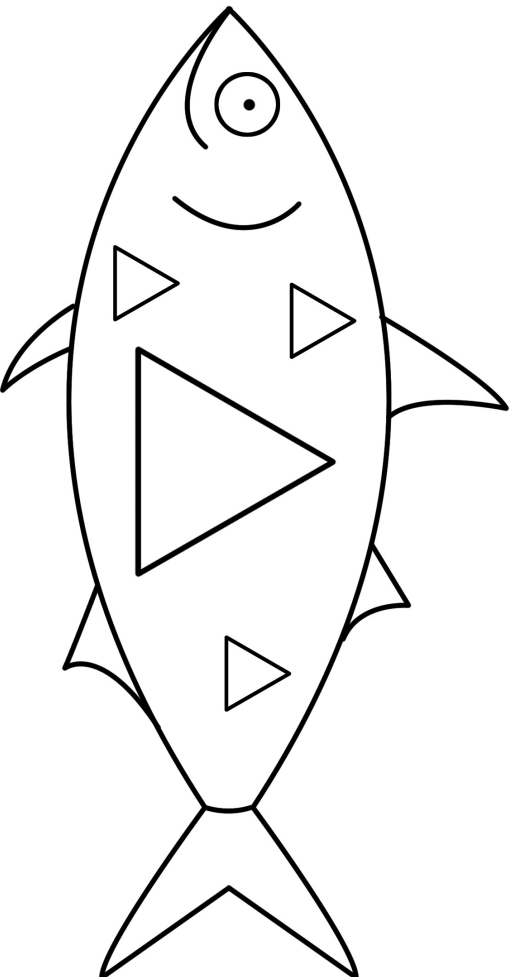
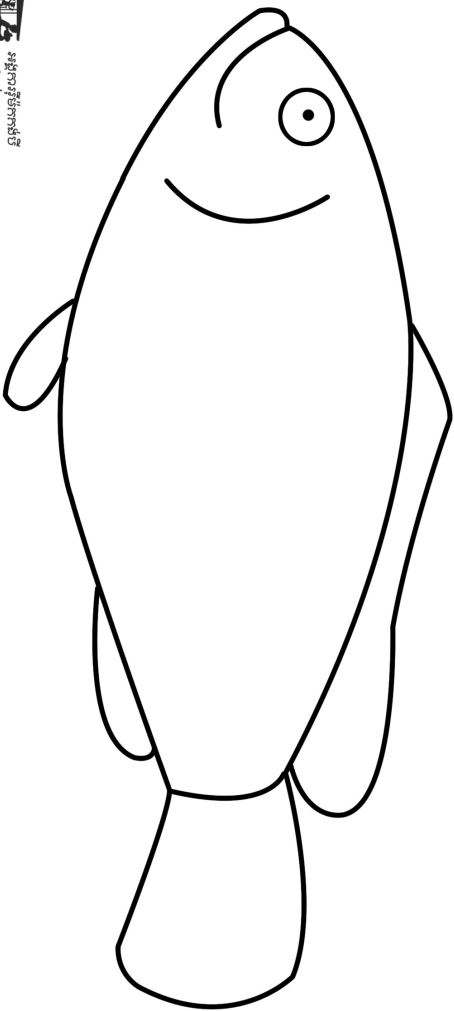
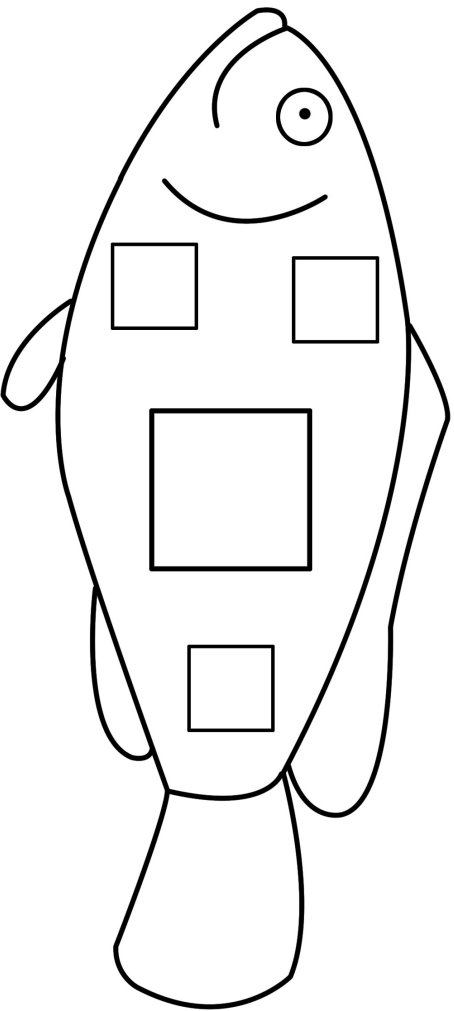

គួររចនាម៉ូដ ក្រមាដោយសេរី



ស្កេន QR Code

សាលាមត្តេយ្យ ថ្នាក់កម្រិត

ឈ្មោះ : កាលបរិច្ឆេទ

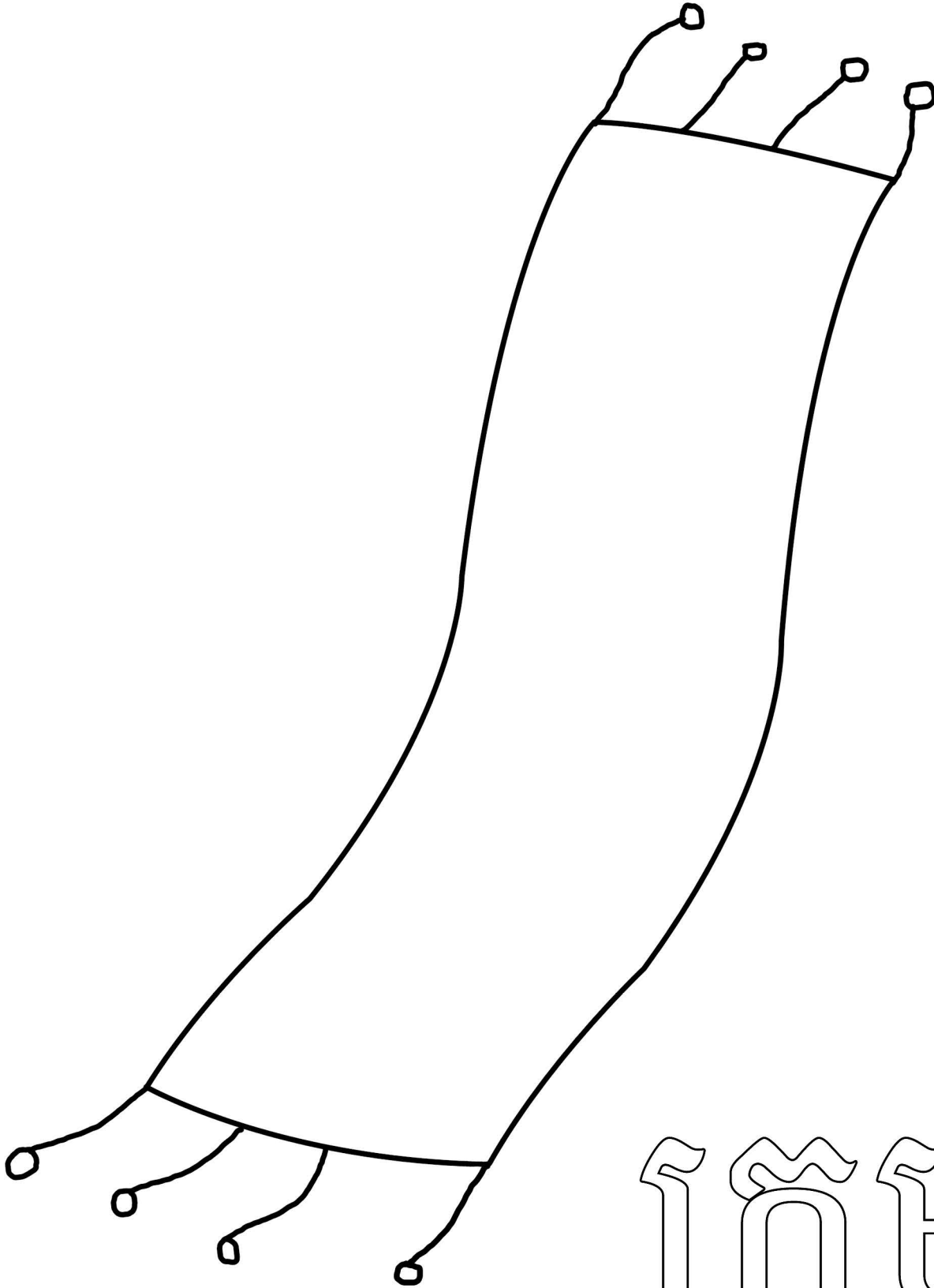

ក្រមា

គូរគំនូរតាមរូបគំរូនៃ ក្រមាជាត់ពណ៌ និងពាក្យ



ស្កេន QR Code

សាលាមត្តេយ្យ ថ្នាក់កម្រិត

ឈ្មោះ : កាលបរិច្ឆេទ

ដើរសរសេររូបគំរូក្រមាមួយណា ដែលអ្នកចង់គូរ

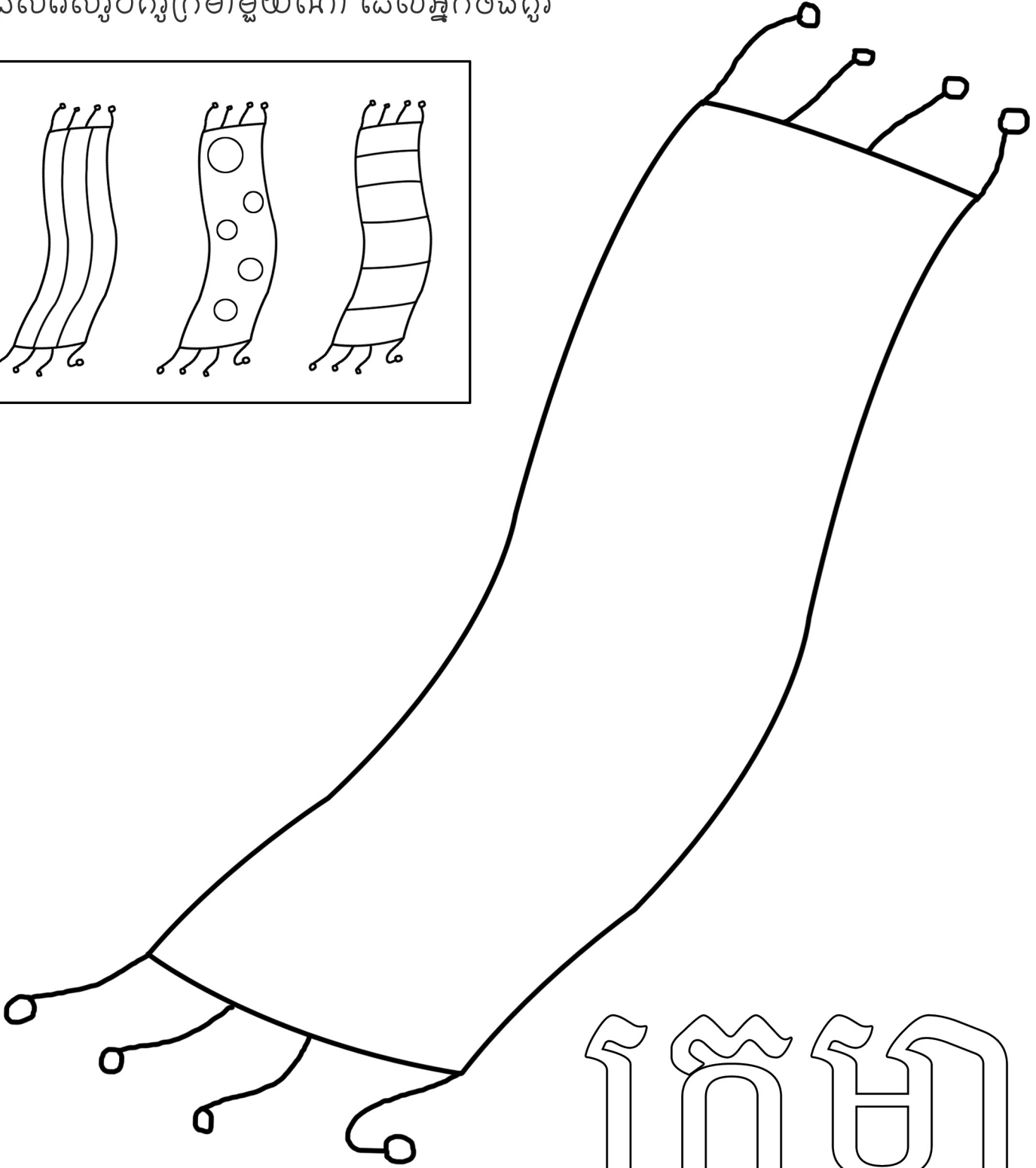
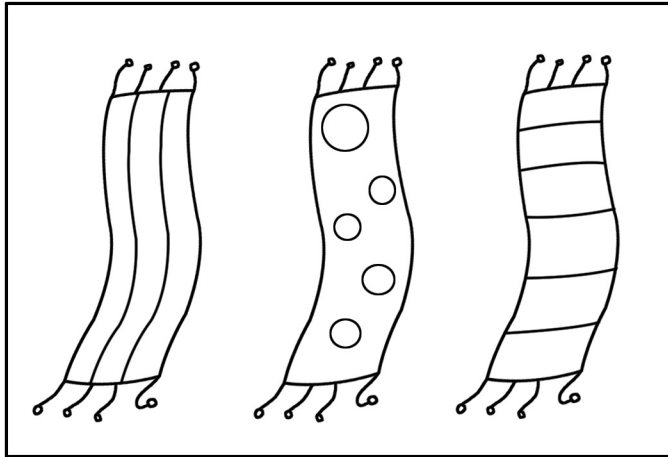

ក្រមា

ផាត់ពណ៌ក្រមា និងពាក្យ



ស្កេន QR Code

សាលាមត្តេយ្យ ថ្នាក់កម្រិត

ឈ្មោះ : កាលបរិច្ឆេទ

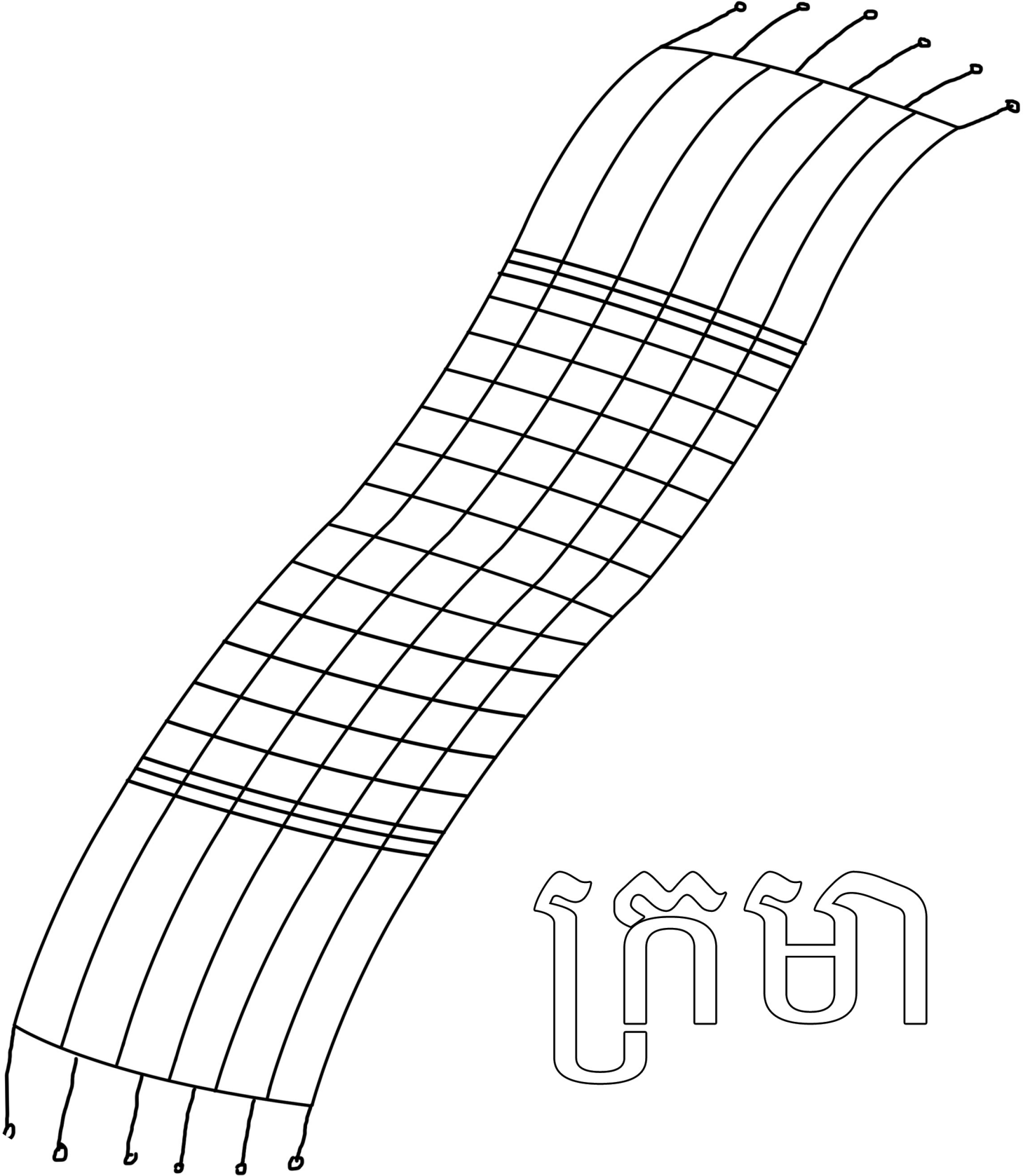

ក្រមា



សកម្មភាពពេលធ្វើនំប៉័ង (បង់លេខតាមលំដាប់លំដោយ)

សាលាមត្តេយ្យ ថ្នាក់ទី.....

ឈ្មោះ : កាលបរិច្ឆេទ :

ស្កេន QR Code

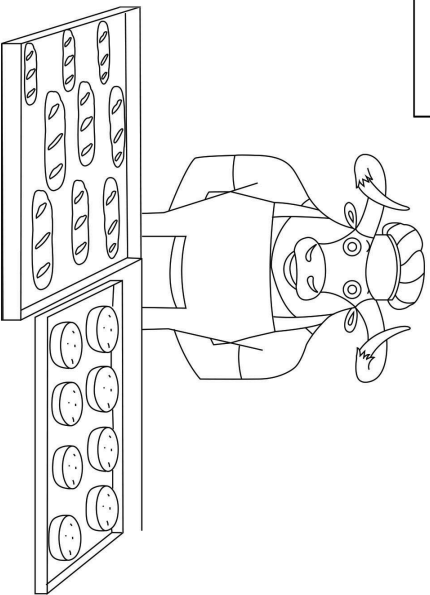
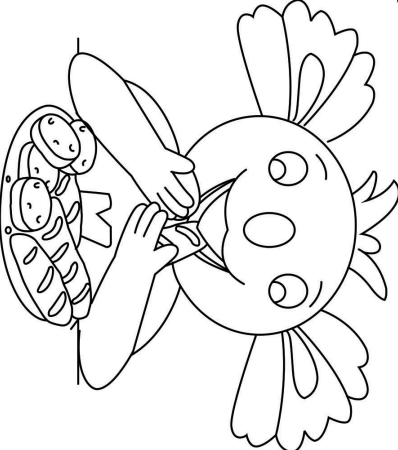
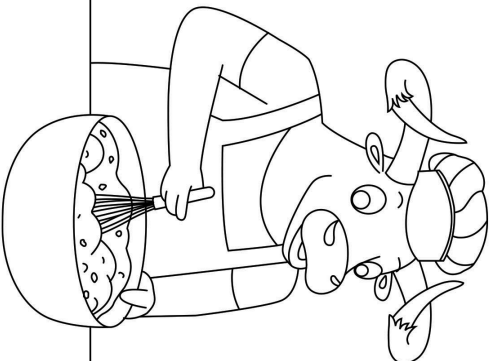
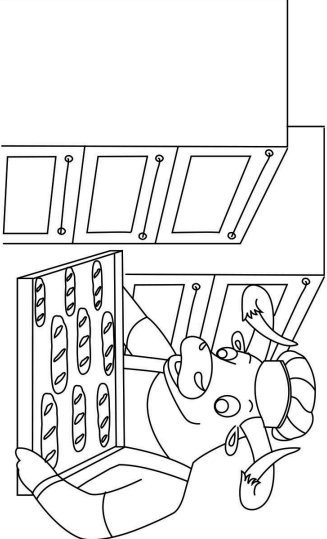

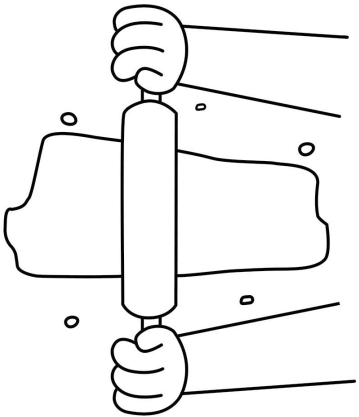
សកម្មភាពពេលធ្វើនំប៉័ង

សាលាមត្តេយ្យ.....
 ឈ្មោះ :

ផ្នែកកម្រិត.....
 កាលបរិច្ឆេទ.....

សៀវភៅ QR Code





សកម្មភាពពេលធ្វើនំប៉័ង

១. កែត្រៃ កាត់ស្និត ខ្លោចដំណើរ និងលើបន្ទាត់ក៏បាន។
២. ដាត់ពណ៌ ឬ មិនបាច់ដាត់ពណ៌ក៏បានដែរ។
៣. កាត់ក្រដាសដាតិរ និងកាត់រូបភាពតាមផ្ទៃក្រ។
៤. យករូបភាពទៅបិទក្រដាសខាងឆ្វេងតាមសំដាប់សំដៅ។



៣

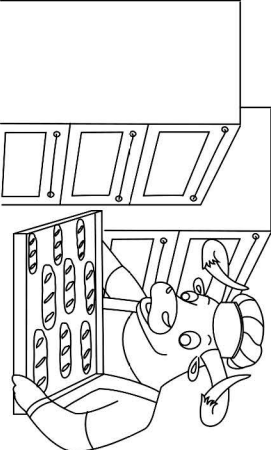

៥

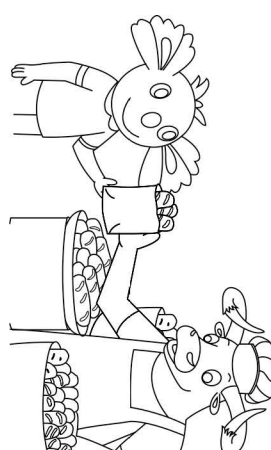

១

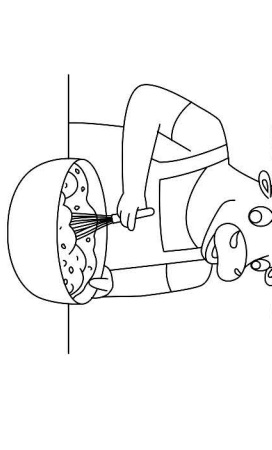

៤

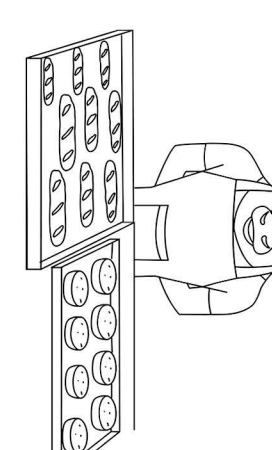

២

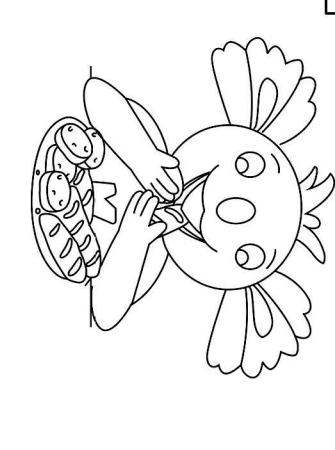

២

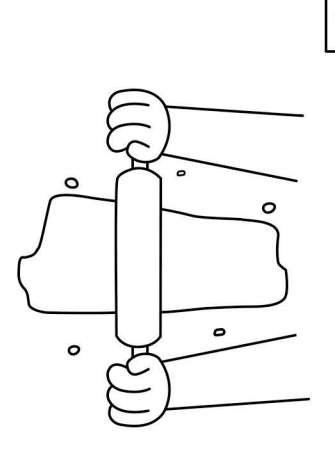

គួររូបការងារងាយៗដែលធ្វើនៅផ្ទះ

សាលាមត្តេយ្យ ថ្នាក់កម្រិត

ឈ្មោះ : កាលបរិច្ឆេទ



ស្កេន QR Code

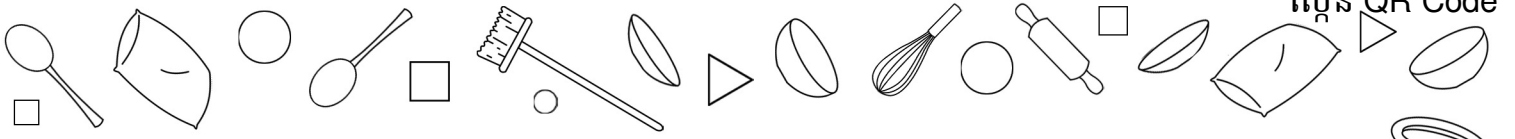

ការងាររបស់ខ្ញុំនៅផ្ទះ...

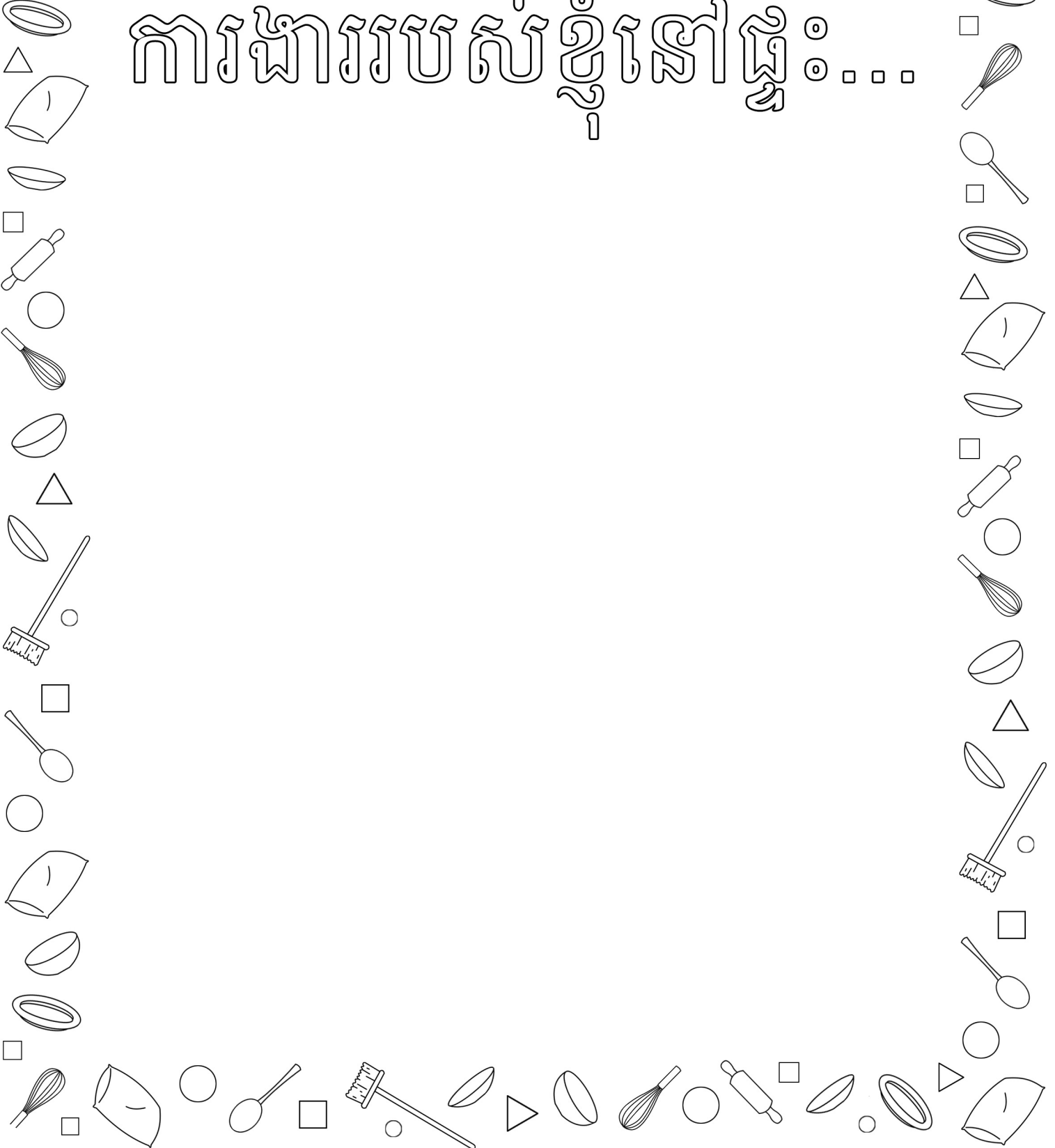

គុសន្ទា បំប្រែករណីទៅនឹងការងារ (អ្នកធ្វើនំប៉័ង និង គ្រូពេទ្យ)



ស្ដែន QR Code

សាលាមត្តេយ្យ ថ្នាក់កម្រិត

ឈ្មោះ : កាលបរិច្ឆេទ

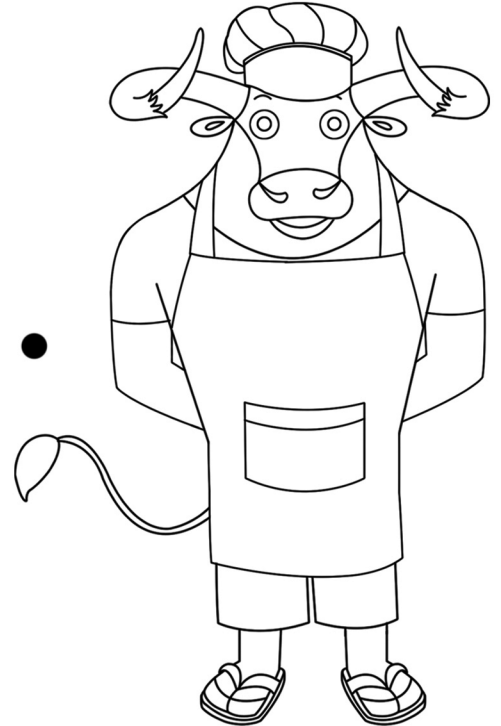
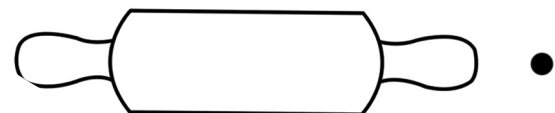
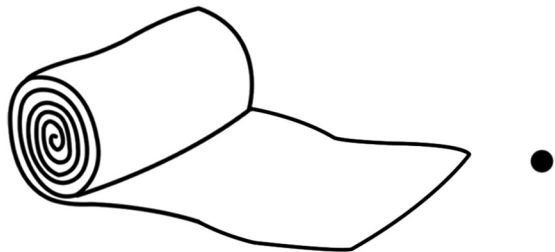
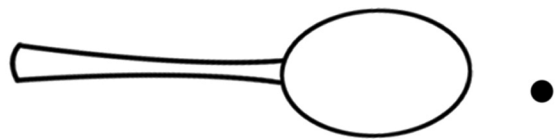
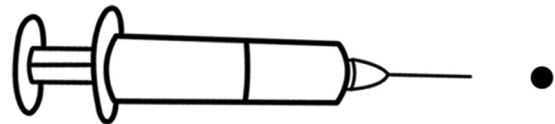
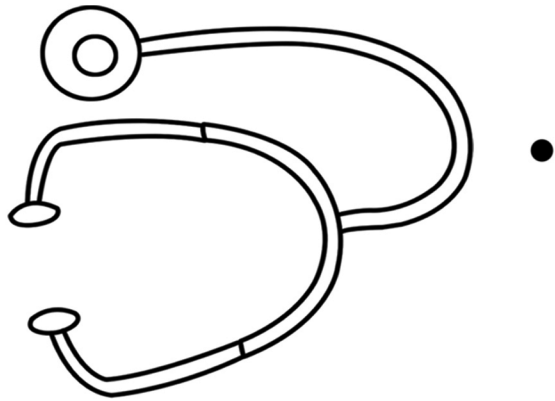
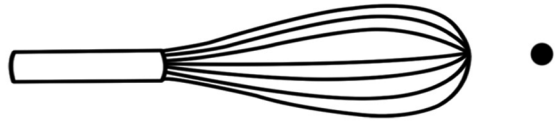

អ្នកធ្វើនំប៉័ង

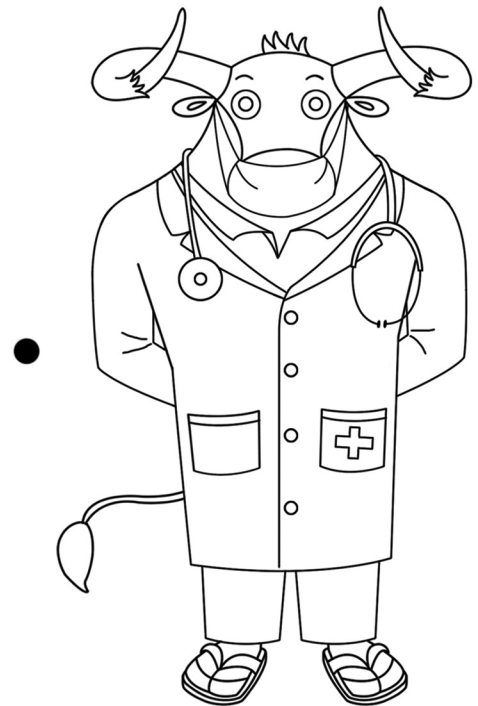

គ្រូពេទ្យ

គូសគ្នា បំបែកករណីទៅនឹងការងារ (ជាងកាត់ដេរ និងជាងជួសជុលម៉ូតូ)



ស្កេន QR Code

សាលាមត្តេយ្យ ថ្នាក់កម្រិត

ឈ្មោះ : កាលបរិច្ឆេទ

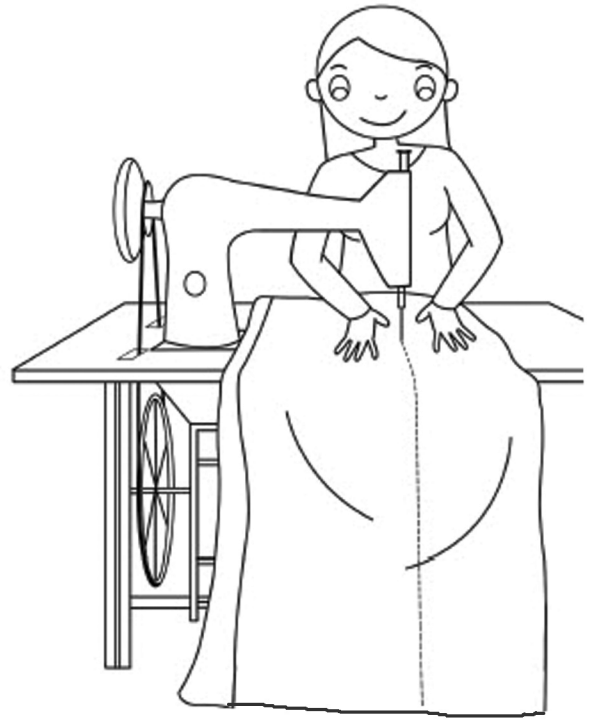
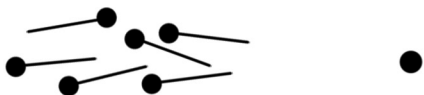
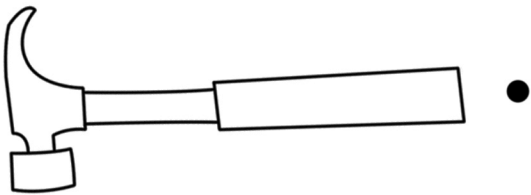
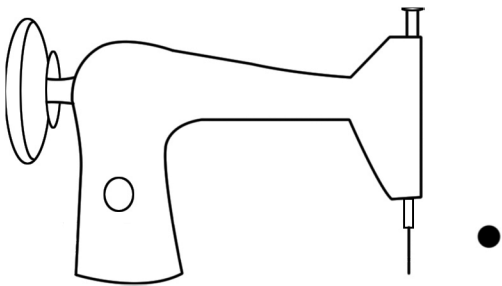
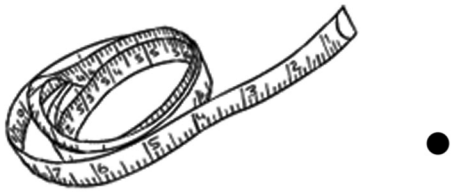
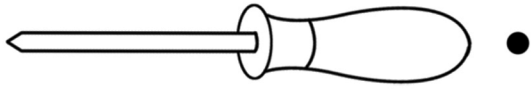

ជាងកាត់ដេរ

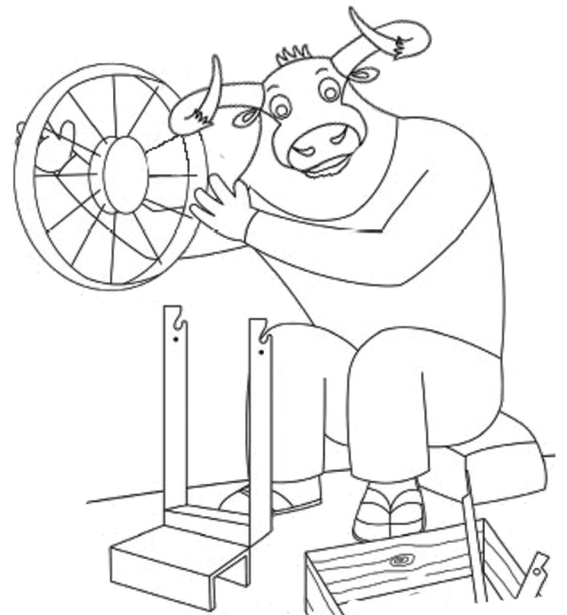

ជាងជួសជុលម៉ូតូ

គូសភ្ជាប់ឧបករណ៍ទៅនឹងការងារ (អ្នកធ្វើអំបិល និងជាងថតរូប)



ស្កេន QR Code

សាលាមត្តេយ្យ ថ្នាក់កម្រិត

ឈ្មោះ : កាលបរិច្ឆេទ

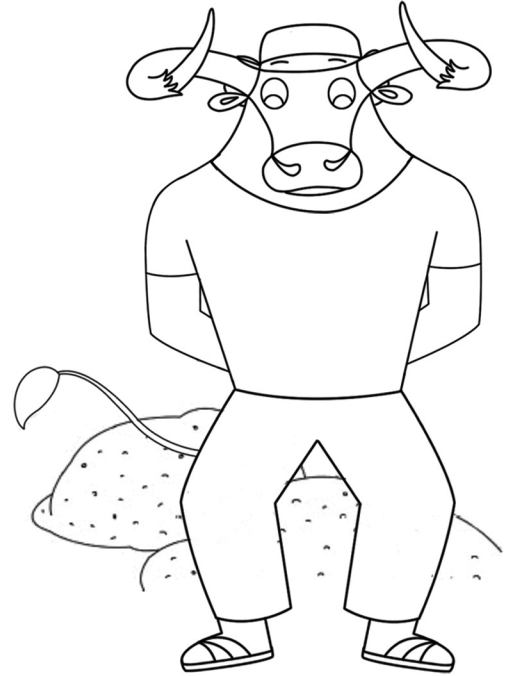
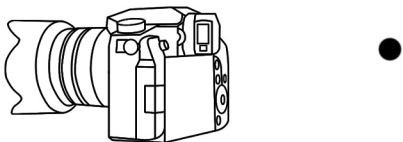
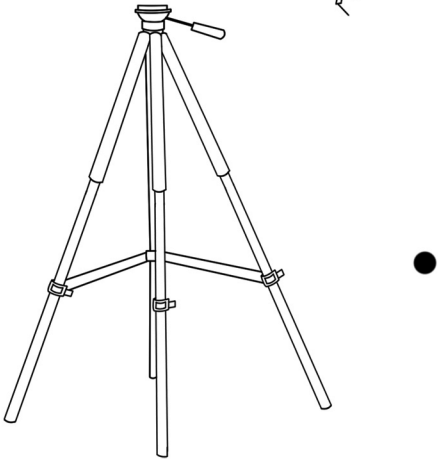
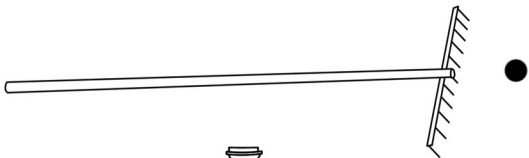
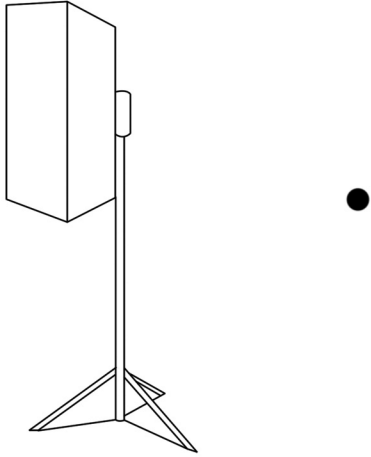
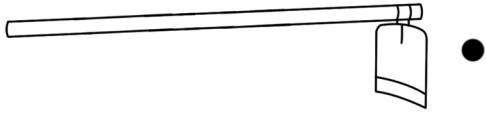

អ្នកធ្វើអំបិល



ជាងថតរូប

ត្រួតពិនិត្យបញ្ជីសេវាសាធារណៈ

សេវាសាធារណៈ ៖

ឈ្មោះ ៖

ស្នាក់នៅ ៖

អាសយដ្ឋាន ៖

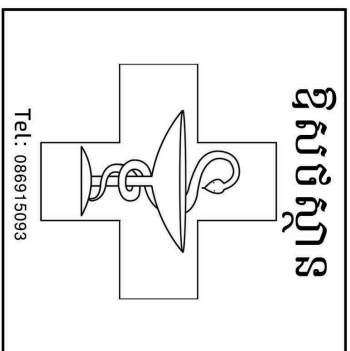
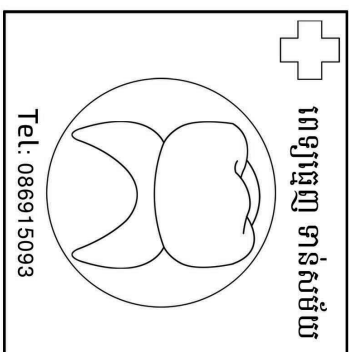
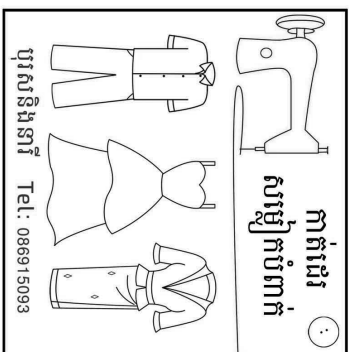
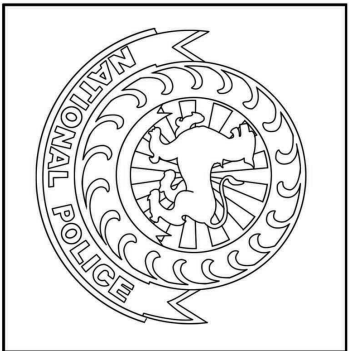
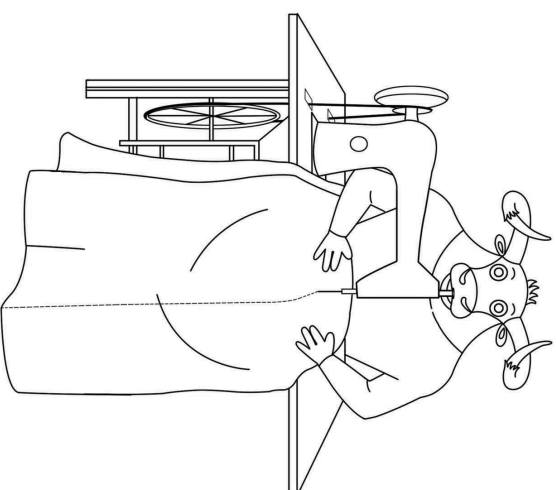
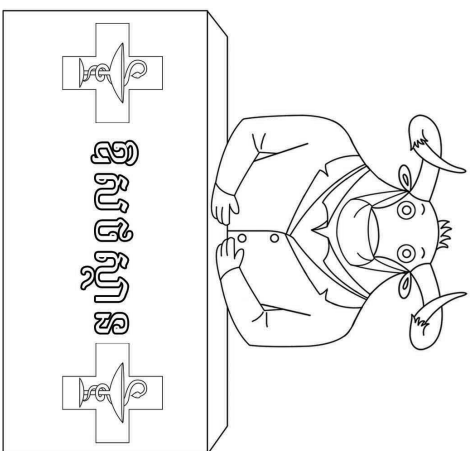
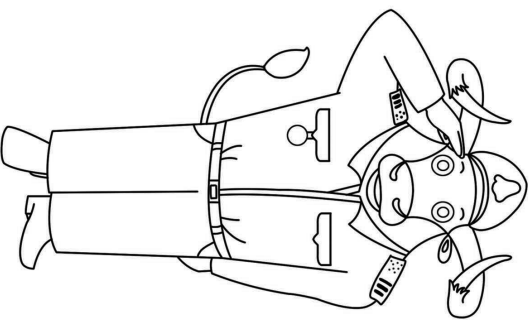
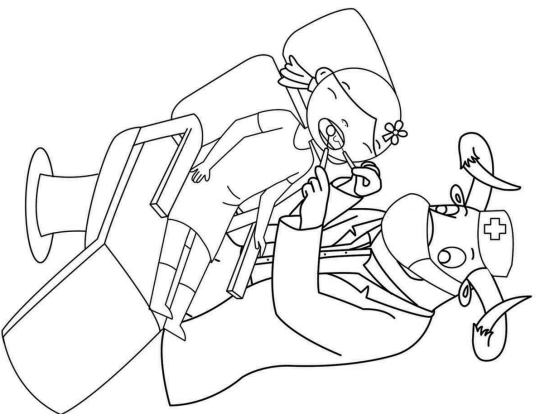

វិទ្យុបង្កើនបរិយាកាស

សាលាបណ្ណាល័យ យ្យ ថ្នាក់កម្រិត

ឈ្មោះ : កាលបរិច្ឆេទ

សៀវភៅ QR Code

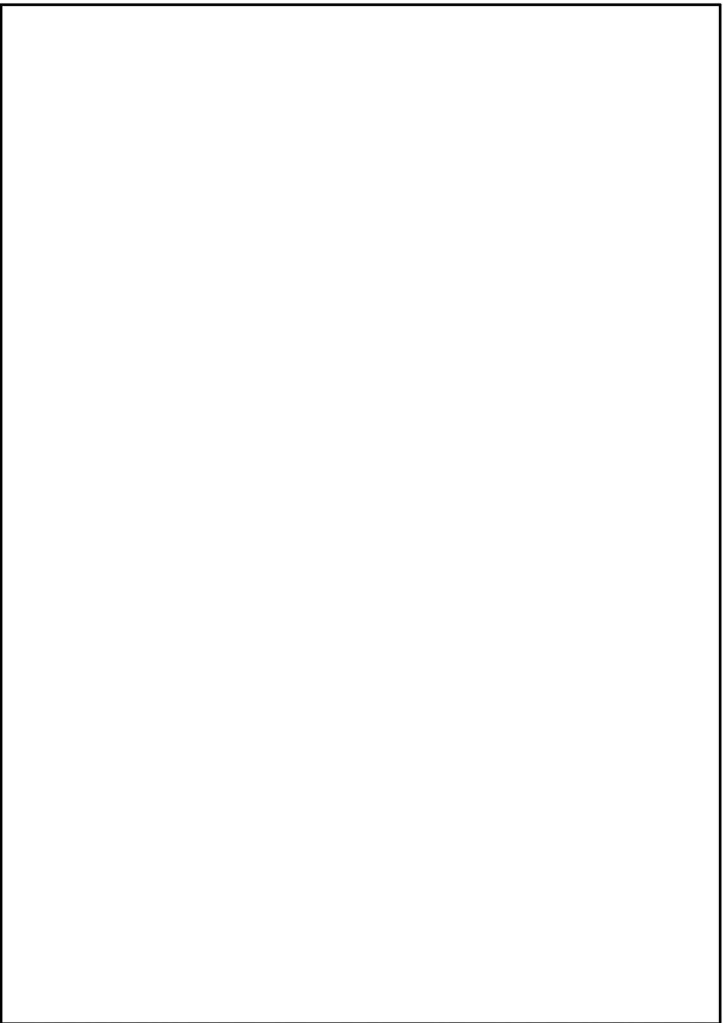
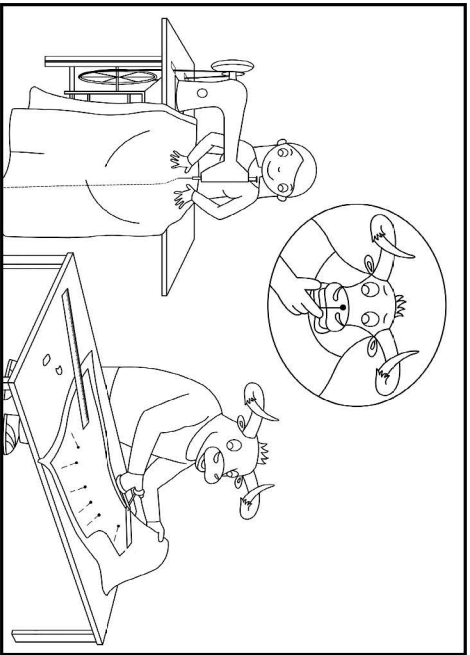

វិទ្យុបង្កើនបរិយាកាស

១. កាត់ក្រដាសជាពីរ។

២. កាត់ប្រដាប់ទាំងប្រាំដំបូលនៅខាងក្រោម ។

៣. ហើយយកកញ្ចប់ទៅផ្គត់ផ្គង់ប្រដាប់ទាំងប្រាំដំបូលឱ្យបានត្រឹមត្រូវ។

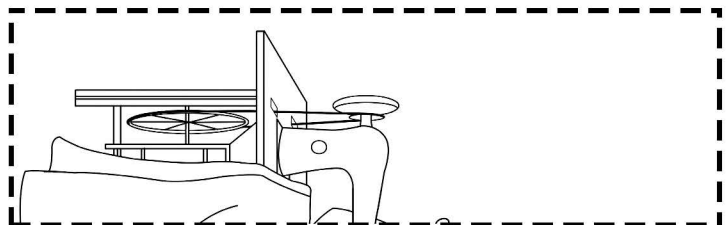
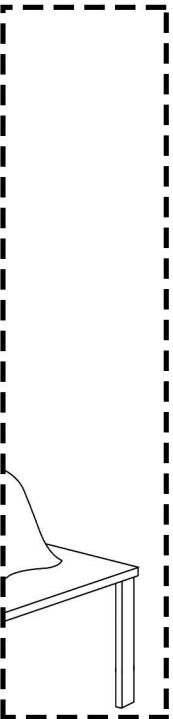
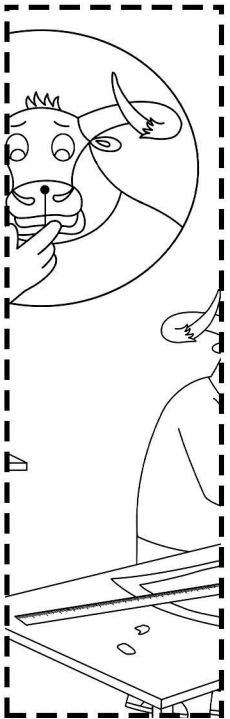
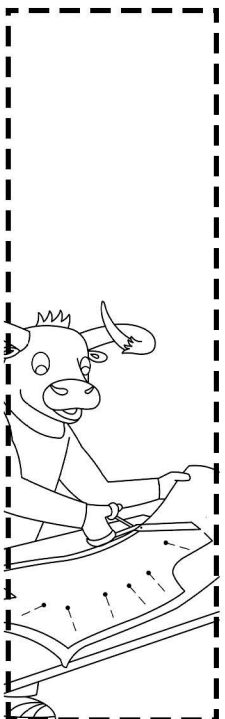
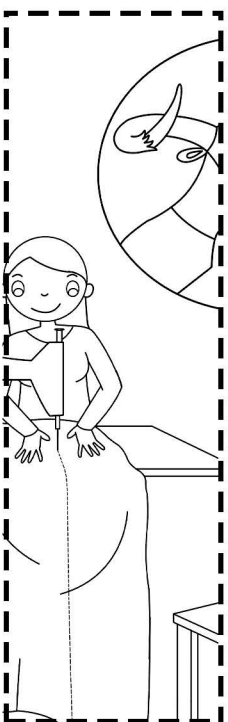

វិទ្យុបង្កើនបរិយាកាស

សាលាបណ្ណាល័យ ថ្នាក់ទី.....

ឈ្មោះ :

ថ្នាក់ទី..... កាលបរិច្ឆេទ

សៀវភៅ QR Code

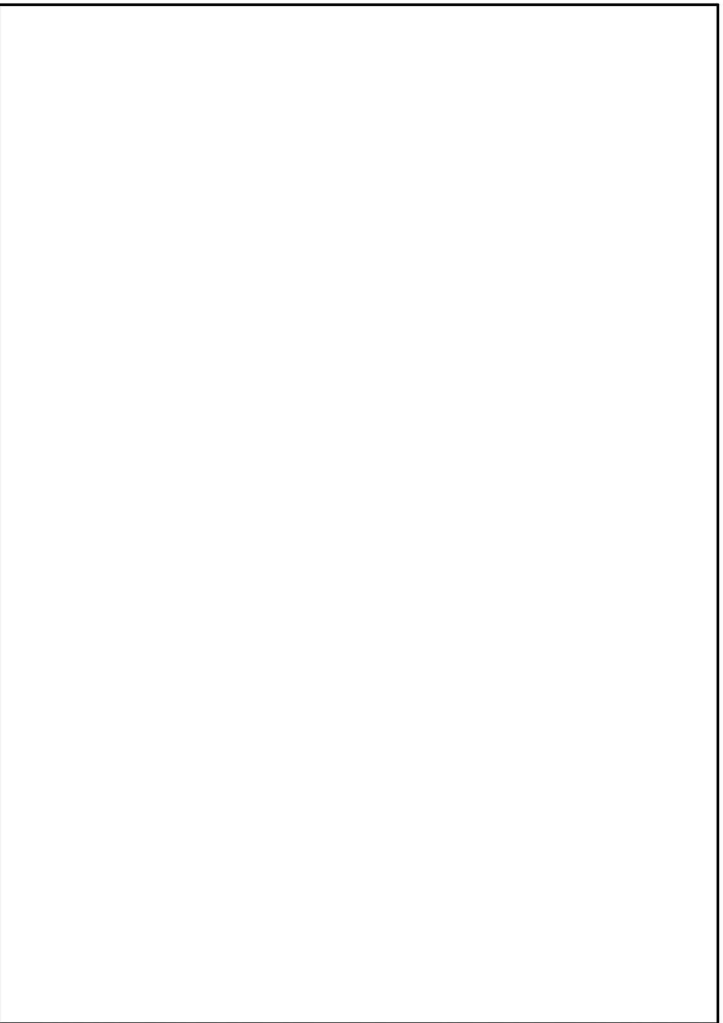
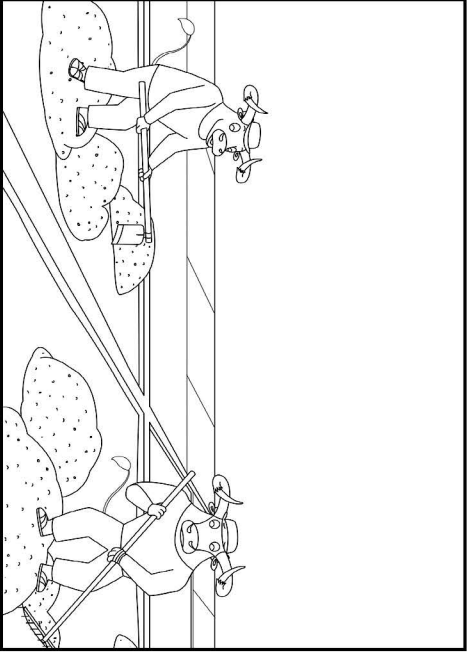

វិទ្យុបង្កើនបរិយាកាស

១. កាត់ក្រដាសជាពីរ។

២. កាត់រូបភាពទាំងបួនដំណាក់កាលនៅខាងក្រោម ។

៣. លើយបកពួកទៅផ្ទៃមុខរូបភាពនៅក្រដាសខាងឆ្វេងឱ្យបានត្រឹមត្រូវ។

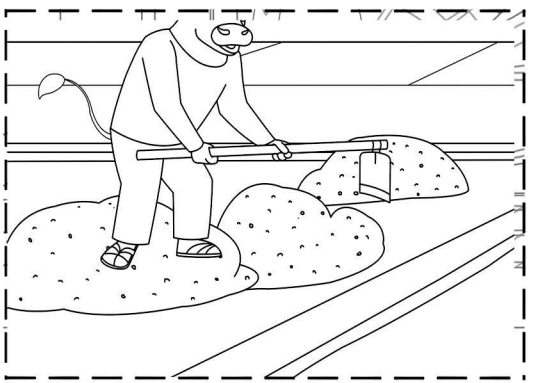
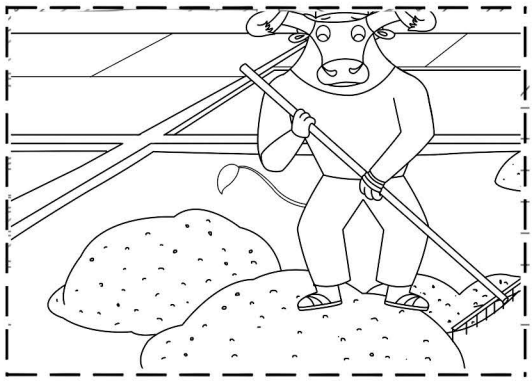
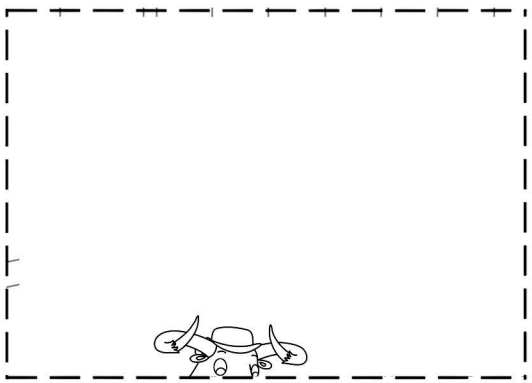

វិទ្យុបង្កើនបរិយាកាស

សាលាមត្តេយ្យ

ឈ្មោះ :

ថ្នាក់ទ្រឹត

កាលបរិច្ឆេទ

សៀវភៅ QR Code

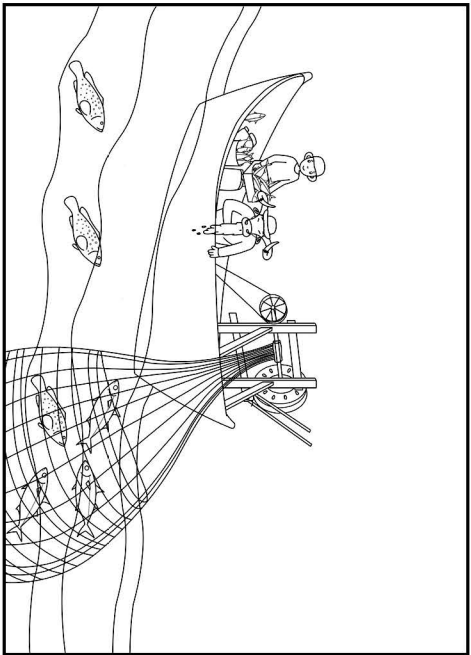

វិទ្យុបង្កើនបរិយាកាស

១. កាត់ត្រដាសជាពីរ។

២. កាត់ប្រហោងទាំងបួនដំលើនៅខាងក្រោម ។

៣. លើយកពួកកេរទៅផ្គិតាមូលប្រហោងនៅត្រដាសខាងឆ្វេងឱ្យបានត្រឹមត្រូវ។

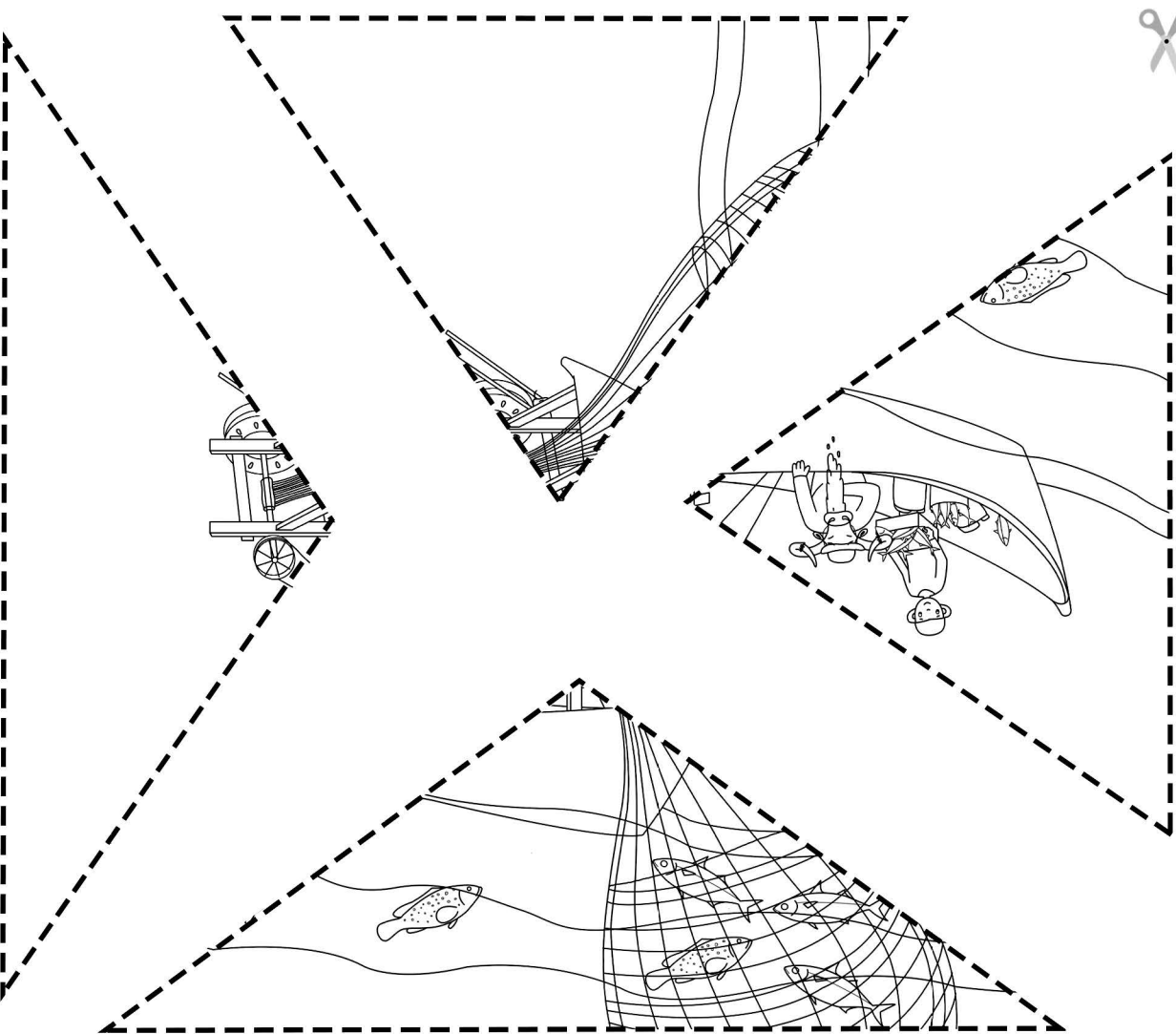

រកចំណុចខុសគ្នា ចំនួនដប់
 រវាងរូបទាំងពីរ និងគូររង្វង់លើរូបភាពនោះ



ស្កេន QR Code

សាលាមត្តេយ្យ ថ្នាក់កម្រិត

ឈ្មោះ : កាលបរិច្ឆេទ

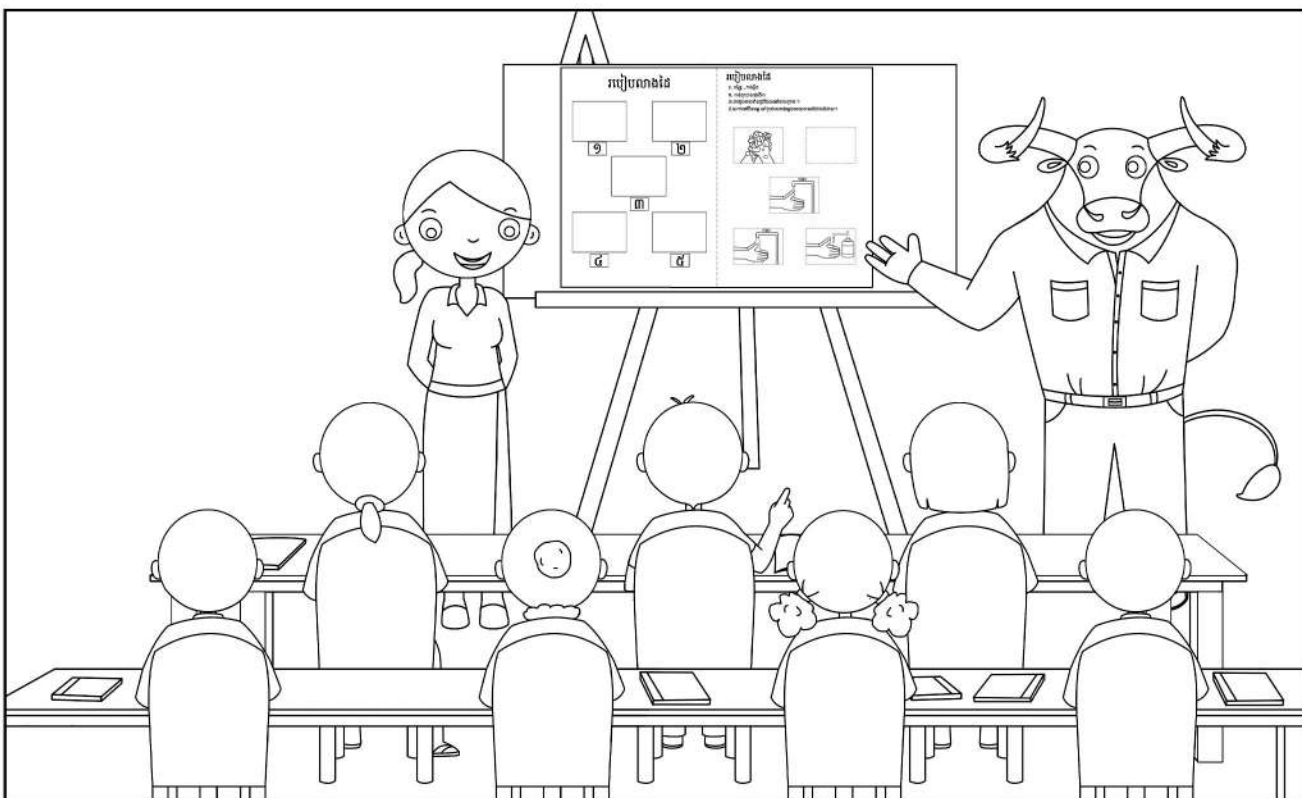
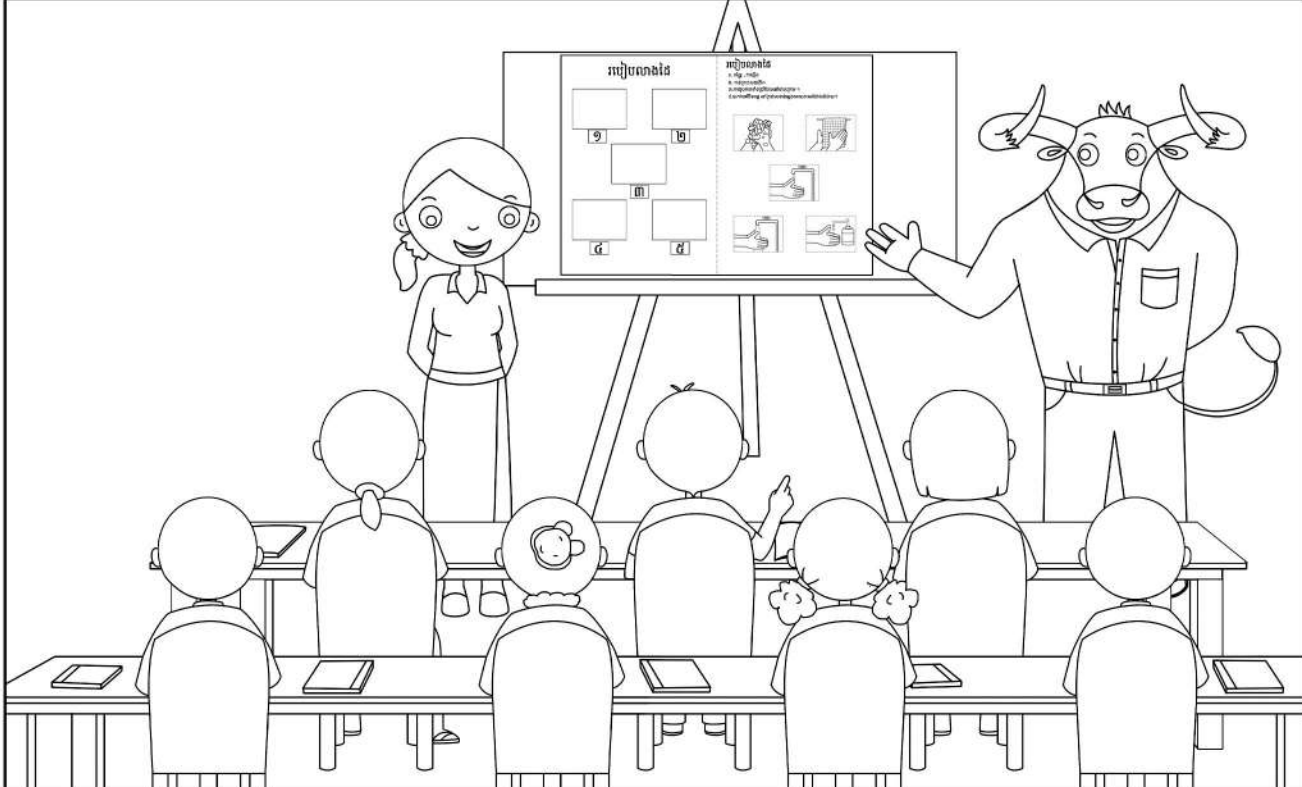

រកចំណុចខុសគ្នា ចំនួនដប់
 រវាងរូបទាំងពីរ និងគូររង្វង់លើរូបភាពនោះ



ស្កេន QR Code

សាលាមត្តេយ្យ ថ្នាក់កម្រិត

ឈ្មោះ : កាលបរិច្ឆេទ

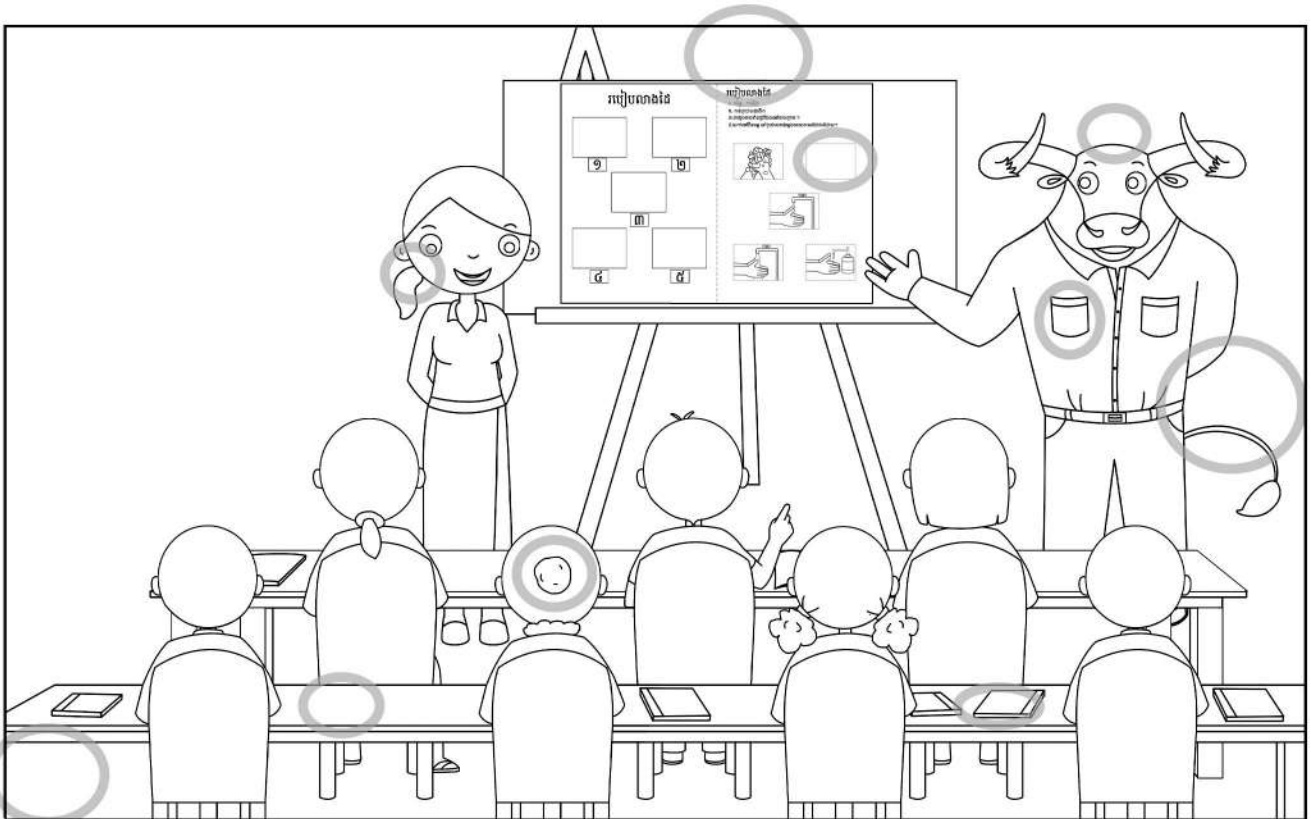
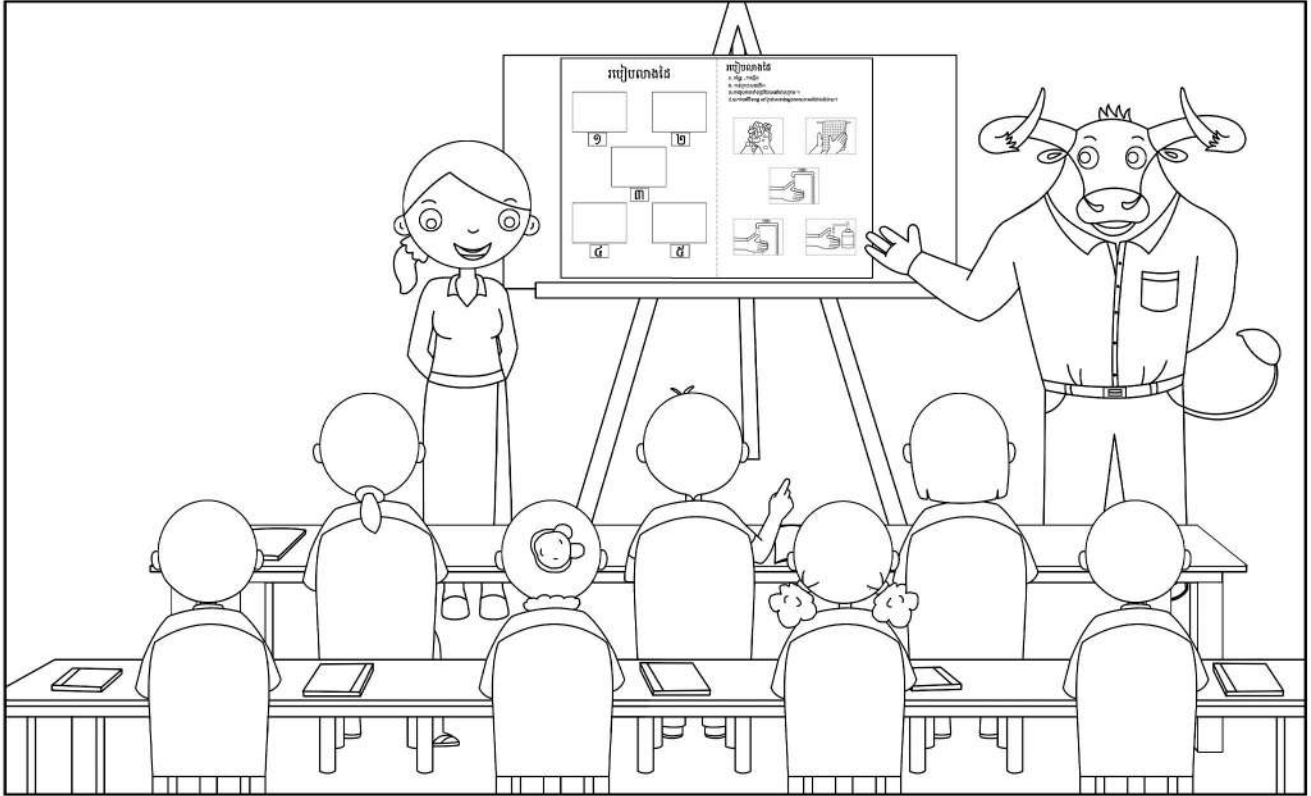

រកចំណុចខុសគ្នា ចំនួន ប្រាំ ពីរ
រវាងរូបទាំងពីរ និងគូររង្វង់ លើរូបភាពនោះ



ស្កេន QR Code

សាលាមត្តេយ្យ ថ្នាក់កម្រិត

ឈ្មោះ : កាលបរិច្ឆេទ

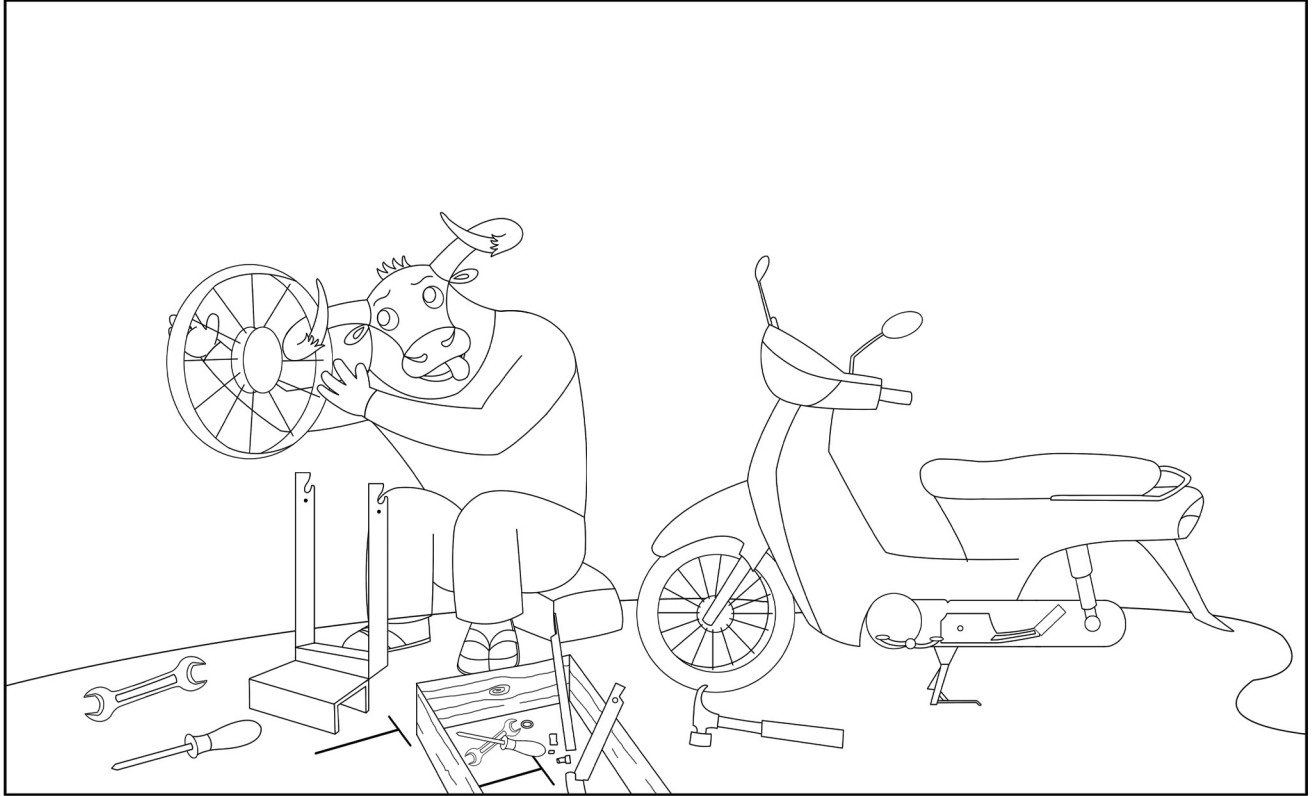

រកចំណុចខុសគ្នា ចំនួន ប្រាំ ពីរ
រវាងរូបទាំងពីរ និងគូររង្វង់ លើរូបភាពនោះ



ស្កេន QR Code

សាលាមត្តេយ្យ ថ្នាក់កម្រិត

ឈ្មោះ : កាលបរិច្ឆេទ

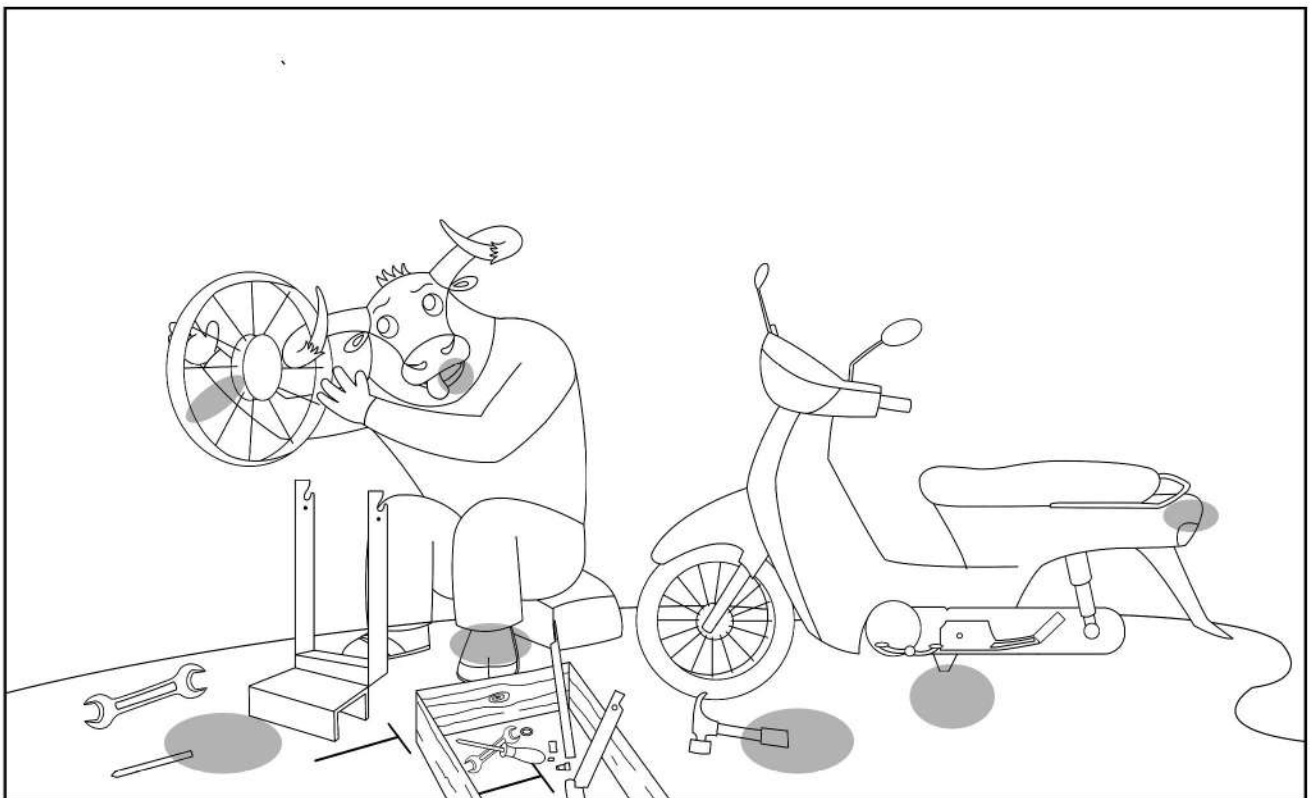
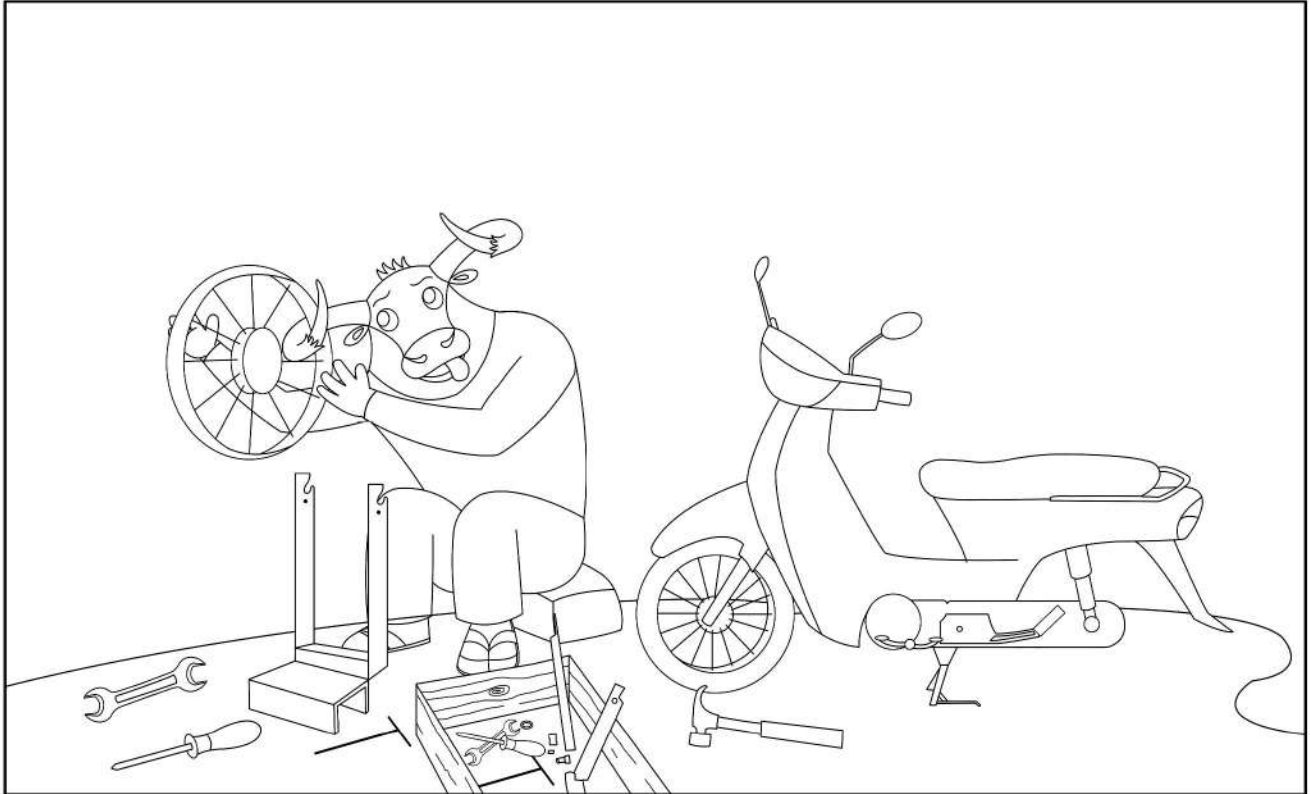

រកចំណុចខុសគ្នា ចំនួន ប្រាំ
 រវាងរូបទាំងពីរ និងគូររង្វង់លើរូបភាពនោះ



ស្កេន QR Code

សាលាមត្តេយ្យ ថ្នាក់កម្រិត

ឈ្មោះ : កាលបរិច្ឆេទ

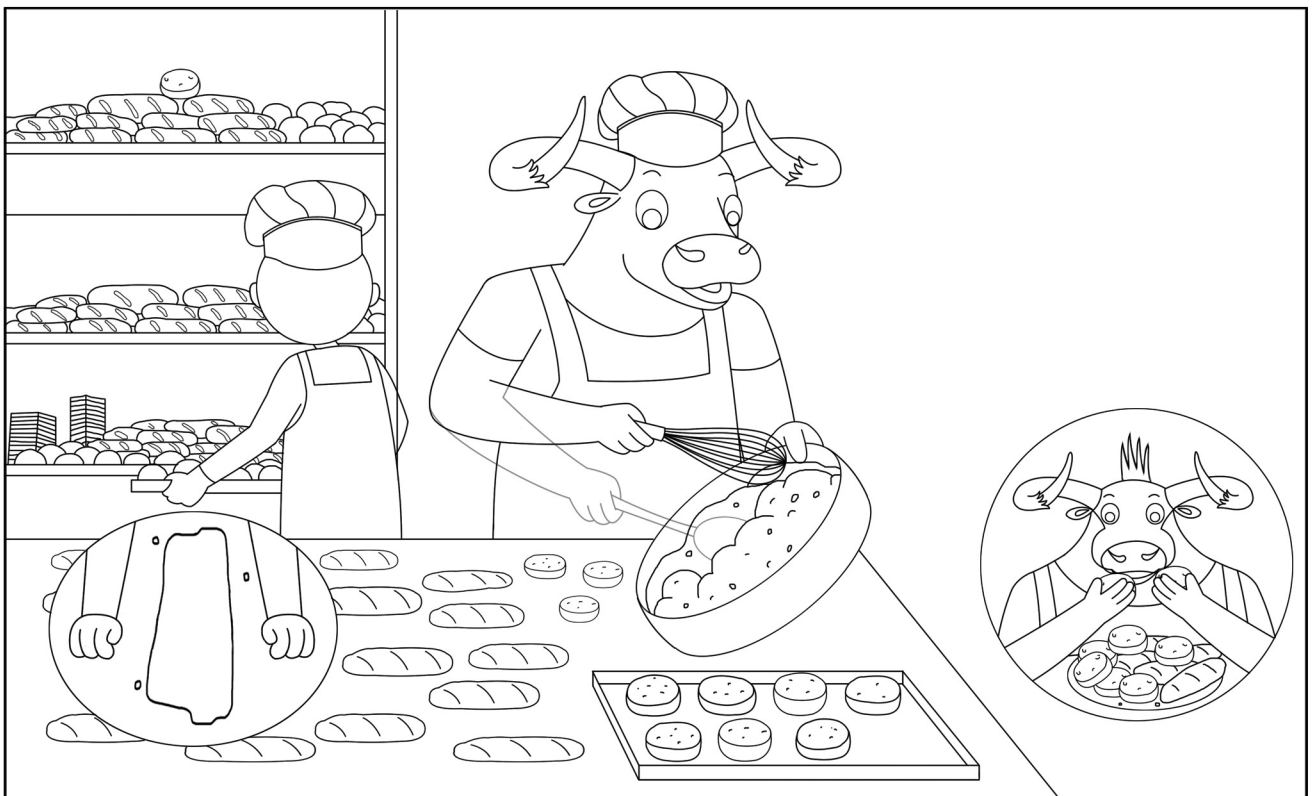
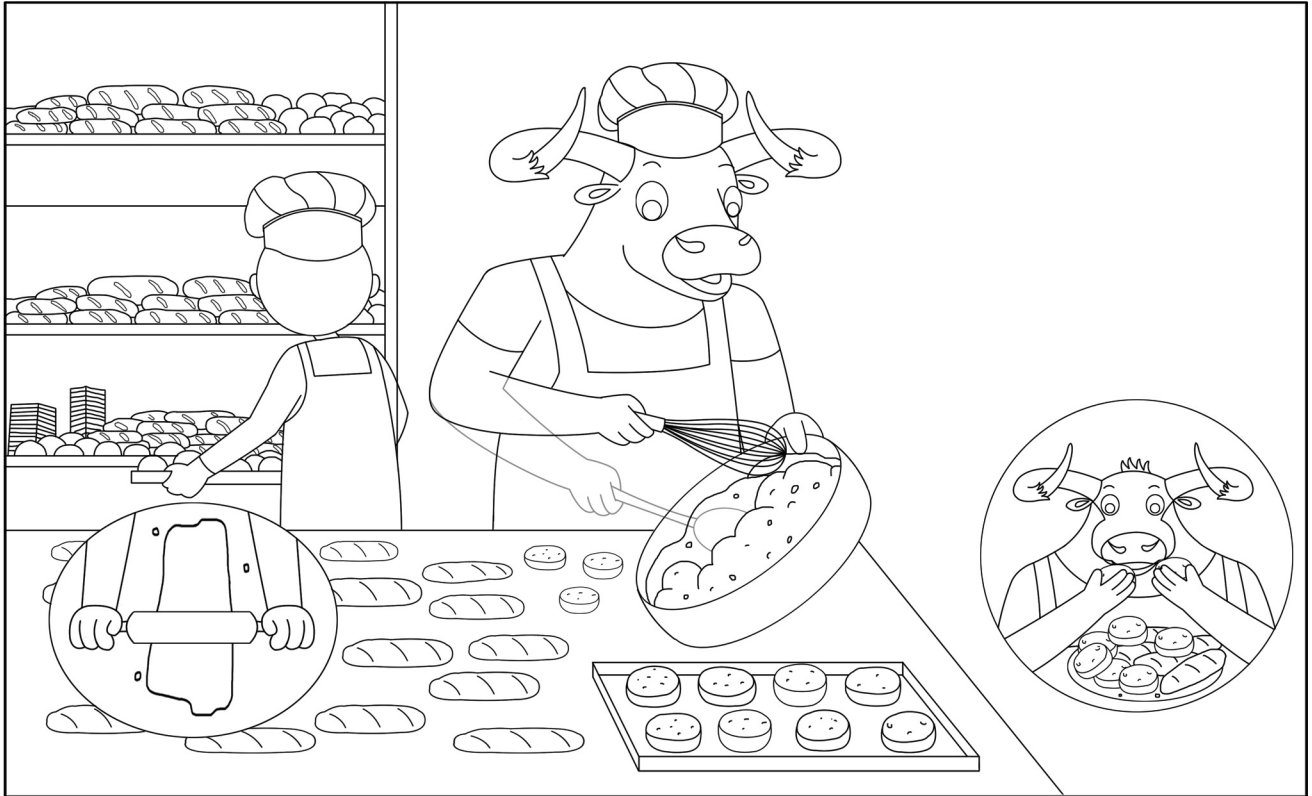

រកចំណុចខុសគ្នា ចំនួន ប្រាំ
 រវាងរូបទាំងពីរ និងគូររង្វង់លើរូបភាពនោះ



ស្កេន QR Code

សាលាមត្តេយ្យ ថ្នាក់កម្រិត

ឈ្មោះ : កាលបរិច្ឆេទ

